

MITSUBISHI-B Project

Title:

Achievable precision with heuristic solvers: quantum algorithms and quantum supremacy

Industrial Partner: Information Technology R&D Center, Mitsubishi Electric Corp.

Mitsubishi Electric is a world leader in manufacturing and sales of electrical and electronic products and systems used in a broad range of fields and applications. As a global leader among green companies, our technologies are being applied to contribute to and support society and daily life around the world. The Information Technology R&D Center is actively creating new businesses through basic research and development in the fields of information technology, media intelligence, electro-optics microwaves, and communication technologies. We are also seeking technologies that reinforce our position on the leading edge of progress, with work to renew existing businesses through the fruits of our R&D in the field of IT.

Industry Mentors

Aruto Hosaka, Ph.D., Researcher, Photonics Platform Group, Advanced Basic Research Dept.

Tsuyoshi Yoshida, Ph.D., Senior Manager, Photonics Platform Group, Advanced Basic Research Dept.

Background:

New computing schemes such as quantum computing have emerged in parallel with the steady evolution of deployable classic computing toward solving various problems much more efficiently. To address the huge problems that arise when one scales to larger problems, heuristic algorithms (and hardware for implementing the algorithms) often are employed. Herein, we have two issues:

- 1) The superiority and inferiority can depend on the problem characteristics or even on random numbers frequently used in the examination.
- 2) The true distance between the obtained and the exact solutions is generally unknown.

While there have been many proposals for new algorithms based on quantum computing, their general performance over a wide range of problems cannot easily be compared because of these issues.

Expectation:

Because of the issues described above, we would like to do the following in this project:

- 1) define a metric to describe how good potentially obtainable solutions are in various (or general) problems, and
- 2) give some mathematical guarantee to the algorithm that are being tested, where we call this "achievable precision," e.g., upper and/or lower bound(s) of residuals from the exact solution if it can be quantified by any means.

In this approach, quantum algorithms, quantum-inspired algorithms, and/or something around those will be treated as heuristic algorithms.

The current state of quantum computing is referred to as the "noisy intermediate-scale quantum (NISQ)" era. Algorithms with variational approaches, including a linear equations solver, have been proposed for exploiting NISQ machines. In such a variational quantum linear solver, the convergence of the solution strongly depends on its initial value given.

Ref. [1] introduced the use of classic preconditioning for helping the convergence performance in a variational quantum linear solver. Fig. 1 illustrates the idea. Fig. 1(a) is a typical schematic of quantum circuit called "ansatz," and Figs. 1(b) and 1(c) show the influence of the preconditioning. In a variational quantum linear solver, the parameters shown in Fig. 1(a) are iteratively updated to solve linear equations $Ax = b$, where the presetting initial values is a key to good convergence. Then preconditioning is expected to improve the convergence performance in a variational quantum linear solver (Fig. 1(b)) as well as ones used in classic computing such as Krylov subspace methods (Fig. 1(c)).

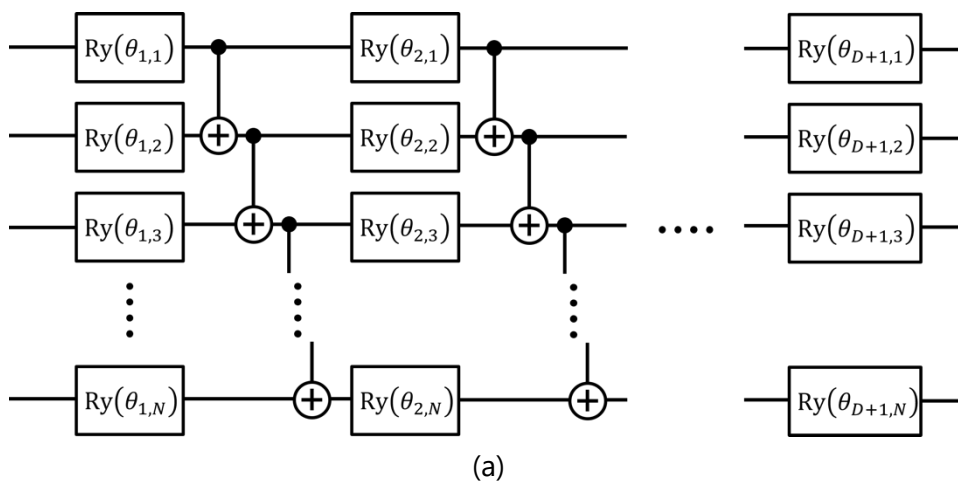

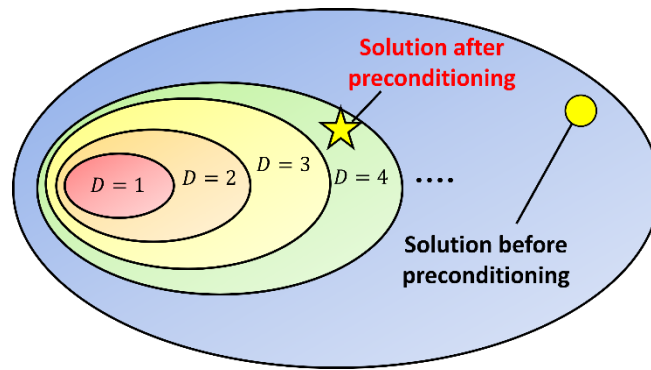

(b)

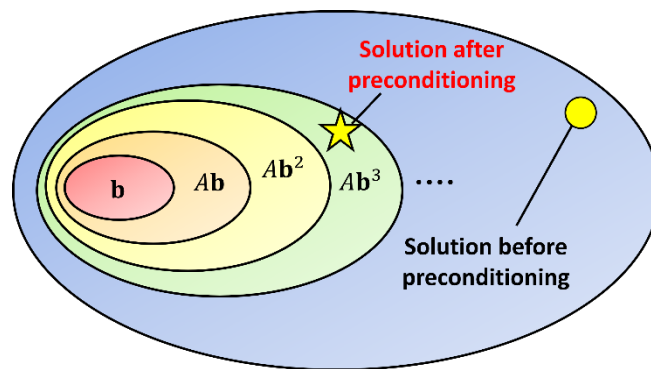

(c)

Fig. 1: Ideas of a variational quantum linear solver with preconditioning: (a) ansatz and (b) preconditioning for variational algorithms with NISQ machines, and (c) Krylov subspace methods in classic computing [1, Fig. 1].

Several problems of linear equations were examined by numerical simulations assuming an ideal NISQ machine (i.e., excluding the noise). The results show that the preconditioning with irregular LU decomposition can reduce the residuals (as shown in Figs. 2 and 3). Note that the number of quantum bits (“qubits”), one of the measures in the quantum computing scale, was limited to 7 for problems with $2^7 \times 2^7$ matrices because we emulated quantum computing by a usual classic computer and the emulation required large computational resources. While the exact solution is easily obtained by classic computing in this small problem, quantum computing is expected to have the scalability toward solving huge scale problems because the required number of qubits can potentially be reduced to log scale with maintaining another measure of the “depth.” The depth should be large in terms of giving a high resolution of solution candidates but be small in terms of the noise in quantum computing.

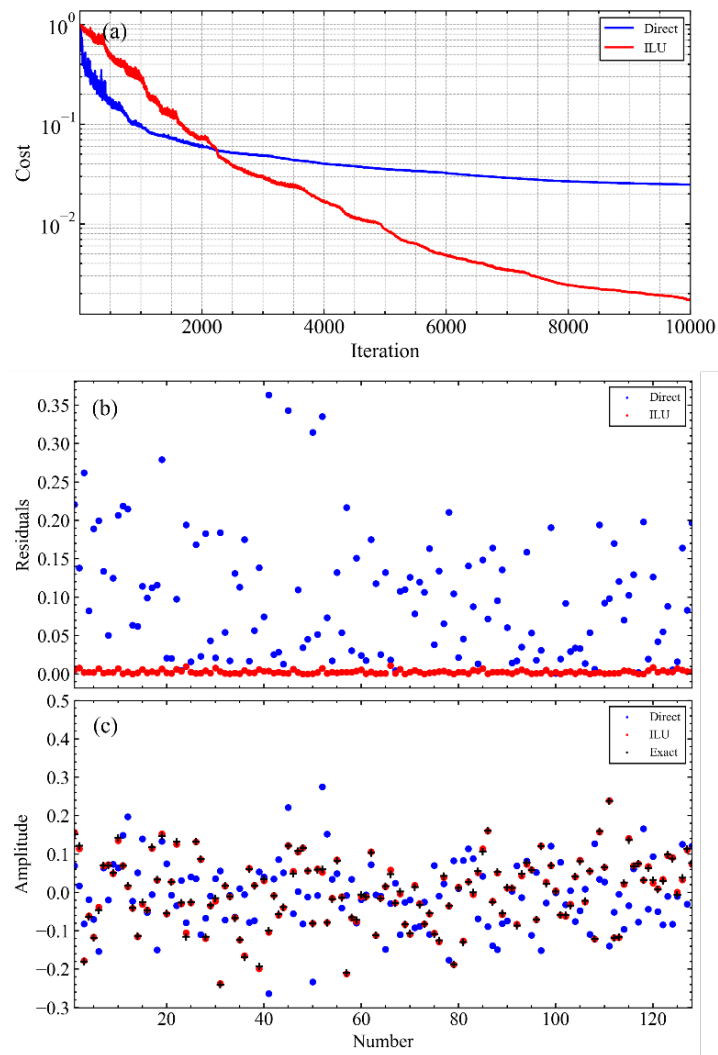

Fig. 2: An example of variational quantum linear solver simulation in cases with ("ILU") and without preconditioning ("Direct"); (a) dependence on the iteration, (b) the distance between the obtained and the exact solutions shown in (c), respectively. [1, Fig. 2].

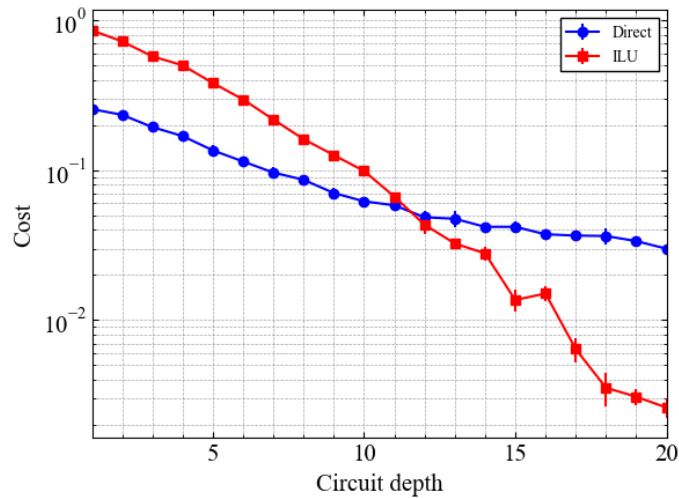

Fig. 3: An example of variational quantum linear solver simulation; dependence on the depth [1, Fig. 3(a)].

A possible conclusion of this g-RIPS project could be that there is no metric as defined in (1) (above) and/or that it is impossible to find a guarantee as defined in (2) (above). On the other hand, it would be a significant scientific achievement (potentially including a guarantee of quantum supremacy from mathematical viewpoints) to be reported in an academic conference or journal when we find something meaningful, even if it is valid only under limited conditions.

Requirements:

- Mandatory: undergraduate-level knowledge in linear algebra.
- Preferable: programming skills. Python codes for [1], which work in usual classic computers, are available.

References:

Fundamentals of variational quantum linear solvers can be found in [2] and [3]. Krylov subspace methods are described in various textbooks such as [4]. For an introduction, we also have access to [5] online. If you need a textbook for quantum computing [6] or ones shown in the website [7] might be useful. For more information regarding this project, please see references shown in our recent work [1].

[1] A. Hosaka et al., "Preconditioning for a variational quantum linear solver," arXiv: 2312.15657 [quant-ph], December 2023.
 Available: www.arxiv.org/abs/2312.15657

[2] C. Bravo-Prieto et al., "Variational quantum linear solver," Quantum, vol. 7, p. 1188,

- November 2023. Available: www.quantum-journal.org/papers/q-2023-11-22-1188
- [3] M. Cerezo et al. "Variational quantum algorithms," *Nature Reviews Physics*, vol. 3, no. 9, pp. 625–644, September 2021.
Available: www.nature.com/articles/s42254-021-00348-9
- [4] Y. Saad, *Iterative methods for sparse linear systems*, Society for Industrial and Applied Mathematics, 2003.
- [5] S. Fan, "An introduction to Krylov subspace methods," arXiv: 1811.09025 [math.OC], November 2018. Available: www.arxiv.org/abs/1811.09025
- [6] M. A. Nielsen and I. L. Chuang, *Quantum computation and quantum information: 10th Anniversary Edition*, Cambridge University Press, 2010.
- [7] The Quantum insider, "7 Quantum Computing Books To Read In 2022 [Ranked & Reviewed]," [Online]. Available: www.thequantuminsider.com/2020/05/15/7-quantum-computing-books-for-the-uninitiated